

SCHOTTKY RECTIFIER

PRELIMINARY DATASHEET

- VERY SMALL CONDUCTION LOSSES
- NEGLIGIBLE SWITCHING LOSSES
- LOW FORWARD VOLTAGE DROP
- LOW THERMAL RESISTANCE
- EXTREMELY FAST SWITCHING
- SURFACE MOUNTED DEVICE

DESCRIPTION

Dual center tap schottky rectifier suited for switch-mode power supply and high frequency DC to DC converters.

Packaged in SOT 223, this device is intended for surface mounting and use in low voltage, high frequency inverters, free wheeling and polarity protection applications.

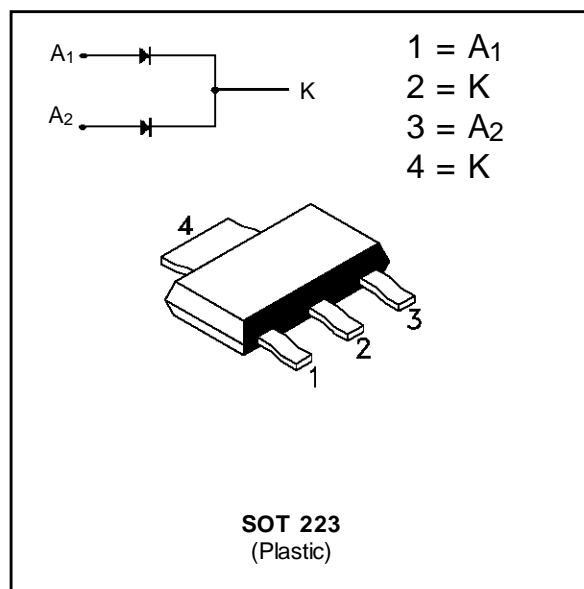

ABSOLUTE RATINGS (limiting values)

Symbol	Parameter		Value	Unit
V _{RRM}	Repetitive Peak Reverse Voltage		60	V
I _{F(RMS)}	RMS Forward Current	Per diode	1.4	A
I _{F(AV)}	Average Forward Current	T _L = 130°C δ = 0.5 Per diode Per device	1 2	A
I _{FSM}	Surge Non Repetitive Forward Current	tp = 10 ms Sinusoidal Per diode	10	A
I _{RRM}	Peak Repetitive Reverse Current	tp = 2 μs F = 1KHz Per diode	1	A
T _{stg} T _J	Storage and Junction Temperature Range		- 65 to + 150 - 65 to + 150	°C
dV/dt	Critical Rate of Rise of Reverse Voltage		1000	V/μs

THERMAL RESISTANCE

Symbol	Parameter		Value	Unit
R _{TH(j-t)}	Junction to Tab for D.C	Total Per diode	12 20	°C/W
R _{TH(j-a)}	Junction to Ambient with 5cm ² Copper Surface Under Tab		55	
R _{TH(c)}	Coupling		5	°C/W

When the diodes 1 and 2 are used simultaneously :
 $\Delta T_J(\text{diode } 1) = P(\text{diode } 1) \times R_{TH}(\text{Per diode}) + P(\text{diode } 2) \times R_{TH(c)}$

STPS260CE

ELECTRICAL CHARACTERISTICS

STATIC CHARACTERISTICS (Per diode)

Symbol	Tests Conditions		Min.	Typ.	Max.	Unit
I_R^{**}	$T_j = 25^\circ\text{C}$	$V_R = V_{RRM}$			500	μA
	$T_j = 100^\circ\text{C}$				8	mA
V_F^*	$T_j = 125^\circ\text{C}$	$I_F = 2\text{ A}$			0.82	V
	$T_j = 125^\circ\text{C}$	$I_F = 1\text{ A}$			0.65	
	$T_j = 25^\circ\text{C}$	$I_F = 2\text{ A}$			0.91	

Pulse test : * $t_p = 380\ \mu\text{s}$, duty cycle < 2 %
** $t_p = 5\ \text{ms}$, duty cycle < 2%

To evaluate the conduction losses use the following equation :

$$P = 0.48 \times I_{F(AV)} + 0.17 I_{F(RMS)}^2$$

Voltage (V)	60
Marking	T26

PACKAGE MECHANICAL DATA
SOT223

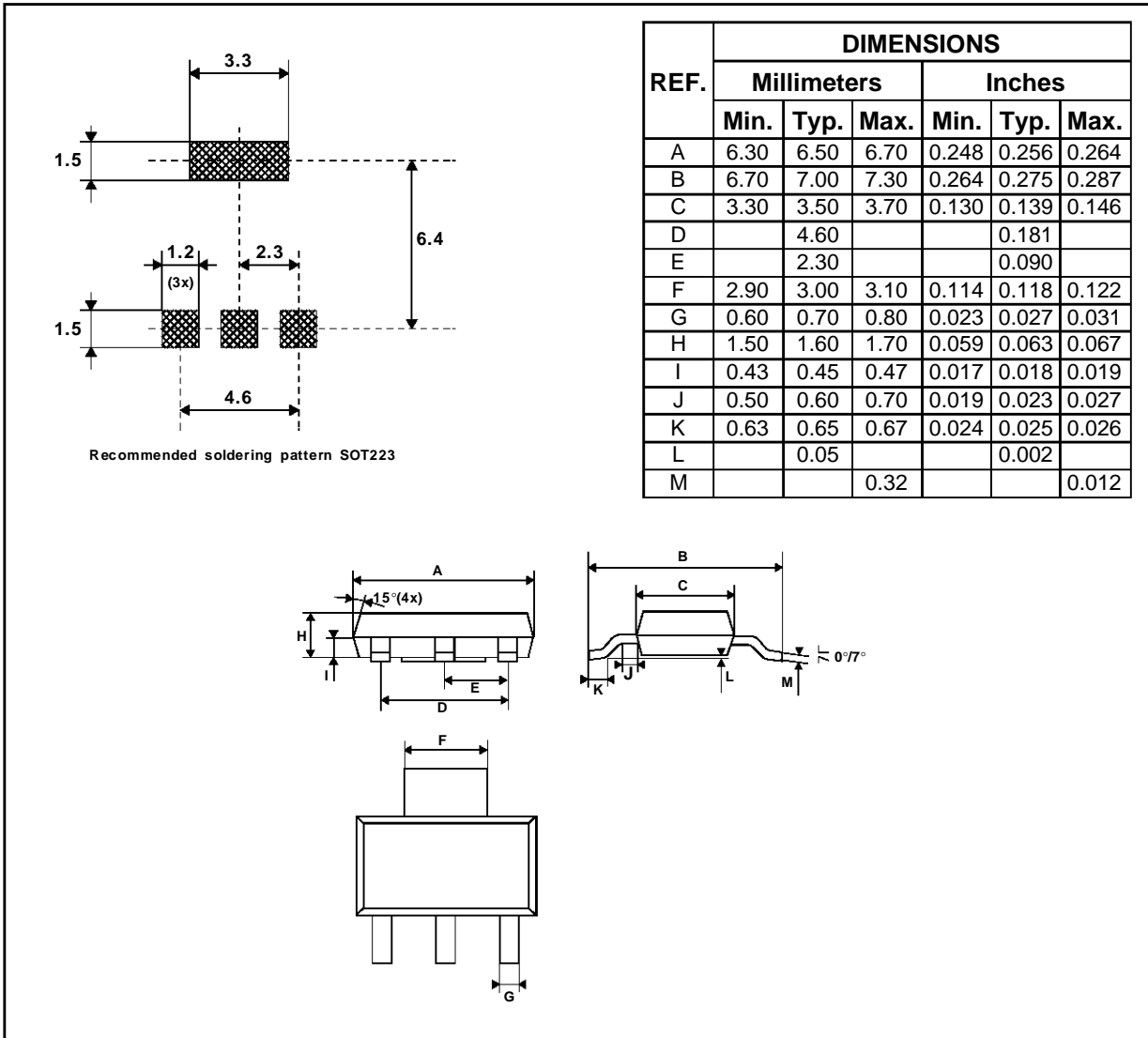

Marking : Type number
Weight : 0.11 g

Information furnished is believed to be accurate and reliable. However, SGS-THOMSON Microelectronics assumes no responsibility for the consequences of use of such information nor for any infringement of patents or other rights of third parties which may result from its use. No license is granted by implication or otherwise under any patent or patent rights of SGS-THOMSON Microelectronics. Specifications mentioned in this publication are subject to change without notice. This publication supersedes and replaces all information previously supplied. SGS-THOMSON Microelectronics products are not authorized for use as critical components in life support devices or systems without express written approval of SGS-THOMSON Microelectronics.

© 1994 SGS-THOMSON Microelectronics - All Rights Reserved

TURBOSWITCH, TRANSIL, TRISIL, SNUBBERLESS are Trademarks of SGS-THOMSON Microelectronics.

SGS-THOMSON Microelectronics GROUP OF COMPANIES
Australia - Brazil - France - Germany - Hong Kong - Italy - Japan - Korea - Malaysia - Malta - Morocco - The Netherlands - Singapore - Spain - Sweden - Switzerland - Taiwan - Thailand - United Kingdom - U.S.A